

Description

The compact 2U 19" Power-D-Box with sockets mounted on a pcb and pre-connected features aluminium profiled cross members with an anodised front plate. The panel cutout accommodates up to 30 positions numbered 1 to 30. It is possible to have 6, 12, 18, 24 or 30 prepared slots or to have a redundant distribution with up to 2 x 15 positions.

The Power-D-Box accommodates plug-in type circuit breakers 3600/3900 and 2210, solid state remote power controller E-1048-700, electronic circuit breaker type ESS20 and electronic circuit protector ESX10. The required device must be specified in the ordering information as both different installation depth and pcb pin assignments must be allowed for.

The devices are plugged into corresponding sockets type 63-P10-Si (6 positions each), soldered onto the pcb and pre-connected.

The system is configured with redundancy as standard (2 x 15 positions), but the two groups may be interconnected so as to provide a non-redundant system if required. Line entry within each group is single pole or double pole.

With single pole line entry all slot numbers per group are combined and connected via an M6 terminal stud by means of a ring cable lug. With double pole line entry, odd and even slot numbers are integrated into separate circuits each of which is connected via 10 mm² screw terminals. This allows use of double pole circuit breakers.

Load outputs are connected by means of screw terminals up to 4 mm² on the rear of the pcb.

The system offers a number of signalisation possibilities and separation for redundancy is also possible:

- series connection of make contacts (group signalisation via closed circuit current)
- parallel connection of break contacts (double sided for group signalisation via closed circuit current)
- parallel connection of break contacts (only one-sided, second side of break contacts will be connected individually with the terminals for single signalisation via closed or open-circuit current)

Termination is on the rear side by means of screw terminals up to 1.5 mm² (group connection) and up to 1 mm² (single signalisation) on the pcb. When using ESS20, ESX10 or E-1048-700, the required Gnd terminals as well as control and reset signals will also be connected via the terminals for group or single signalisation.

Upon request the group distribution (redundancy) can be cancelled by means of jumpers. Additional terminals on the rear side of the rack simplify connection. It is also possible to provide terminals for return lines from the individual loads so as to integrate the necessary external wiring into the rack.

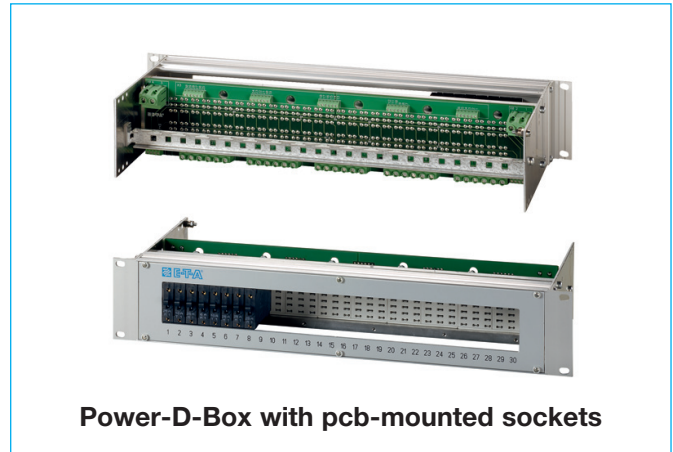

Power-D-Box with pcb-mounted sockets

Technical data

19" Power-D-Box	length: 84 modules (426.72 mm) height: 2 U (88.90 mm) depth: 205...295 mm depending on the version material: aluminium, partly anodized
Front cutout for 30 positions, numbered 1 through 30	1 socket = 6 positions (no. 1 - 6) 2 socket = 12 positions (no. 1 - 12) 3 sockets = 18 positions (no. 1 - 18) 4 sockets = 24 positions (no. 1 - 24) 5 sockets = 30 positions (no. 1 - 30)
Mounting socket	polarised mounting socket type 63-P10-Si (6 positions), soldered onto the pcb from the rear with ring Contact load: 16 A continuously
Line entry X0 Single pole	2 groups, single pole each (= 2 separate circuits) 2 x 100 A max. via terminal stud M6 for ring cable lug
Supply feed X0 Double pole	2 groups, double pole each (= 4 separate circuits) 4 x 40 A max. via screw terminal up to 10 mm ² (max. 4 x 50 A at max. 40 °C ambient temperature)
Load outputs X1	30 channels 16 A max. per pole via screw terminals up to 4 mm ²
Signalisation group signalisation X2	series connection of make contacts / parallel connection of break contacts (double sided) in 2 groups (interconnectable by means of wire bridges) max. 1 A total current via screw terminal up to 1.5 mm ² max. 0.5 A single current via screw terminal up to 1 mm ²
Rated voltage	AC 250 V; DC 65 V
Housing ground/earth	on the inside via M6 screw by means of ring cable lug (two with redundant systems)
Ambient temperature range	0...50 °C

Ordering Information

Type number

19BGT 19" Power-D-Box with sockets pre-wired on pcb

Height

2 2 U = 88.90 mm

Device prepared for accommodation

3600 circuit breaker type 3600 or 3900

2210 circuit breaker type 2210-S

1048 solid state remote power controller E-1048-700

ESS20 electronic circuit breaker type ESS20

ESX10 electronic circuit breaker type ESX10

Number of positions

06 6 poles

12 12 poles

18 18 poles

24 24 poles

30 30 poles

Additional wiring and terminals for line feed

A0 without (only pcb with terminals)

R0 none (only pcb with terminals, redundant)

A2 line feed pre-wired 1-pole
(all positions = 1 circuit)

R2 line entry pre-wired single pole redundant

A3 line feed pre-wired 1-pole
(as A2 + return busbar)

R3 line feed pre-wired 1-pole + return busbar,
redundant

A4 line feed pre-wired 2-pole connected
(all positions = 2 circuits)

R4 line feed pre-wired 2-pole connected, redundant

**Colour for additional wiring, line feed
(not with A0 + R0)**

single pole wiring

SW black

RT red

BL blue

multipole wiring

RB 1st pole red, 2nd pole blue

SB 1st pole black, 2nd blue

Auxiliary contact function

B1 auxiliary contacts connected in series
(group signalisation)

B2 auxiliary contacts connected in parallel
(group signalisation)

B3 auxiliary contacts connected in parallel
(single signalisation)

B5 as B1, with additional wiring (1 mm²)
to terminal (not with A0)

B6 as B2, with additional wiring (1 mm²)
to terminal (not with A0)

**Colour of additional wiring of
auxiliary contacts**

GR grey (only with B5 or B6)

L with printed circuit board
(pcb)

S... **suffix number**
for customer specific
version

19BGT - 2 - 2210 - 24 A2 ... - B1 ... - L S... ordering example

1

Dimensions

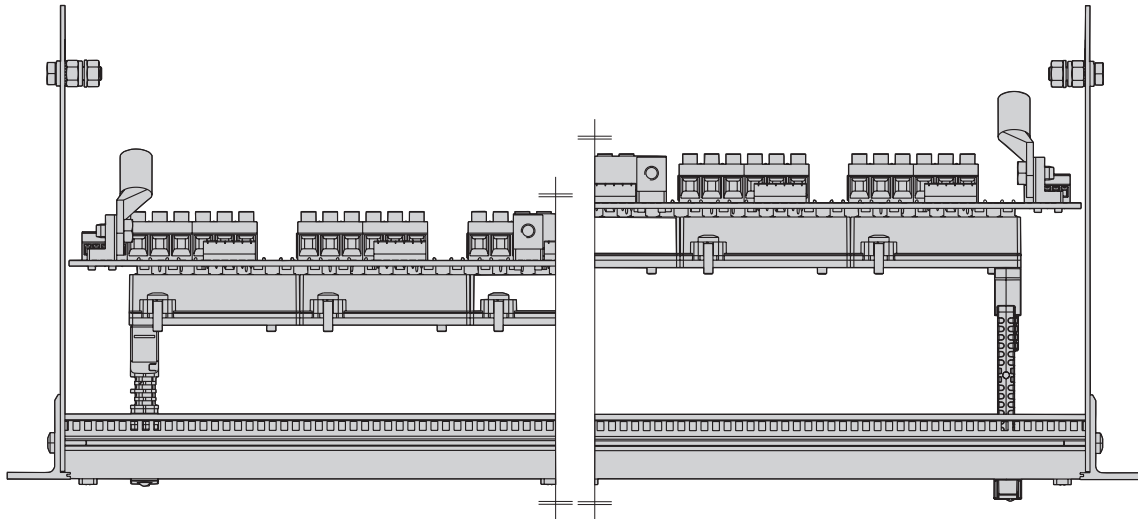
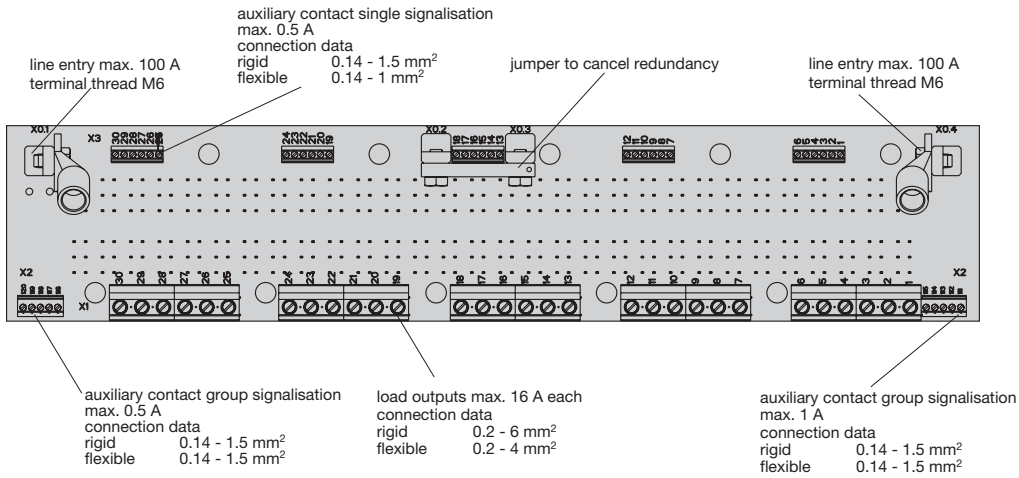

installation depth depending on additional wiring
standard depth 205/250/295 mm

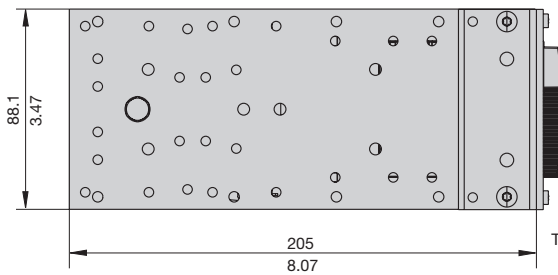

This is a metric design and millimeter dimensions take precedence $\frac{\text{mm}}{\text{inch}}$

Pin assignment bus pcb (terminal side)

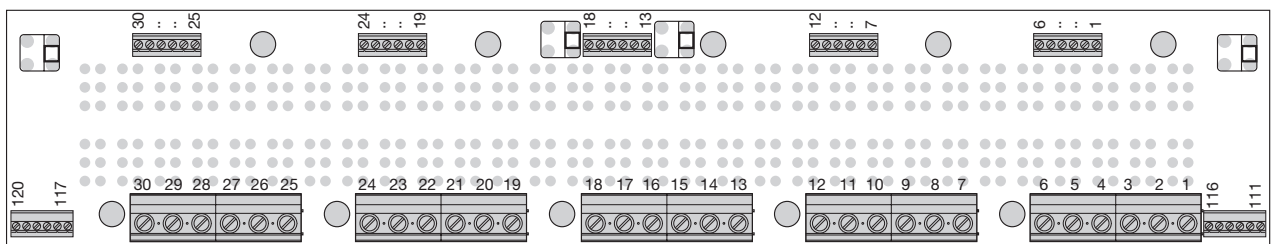

Schematic diagrams

Bus pcb (single pole version)

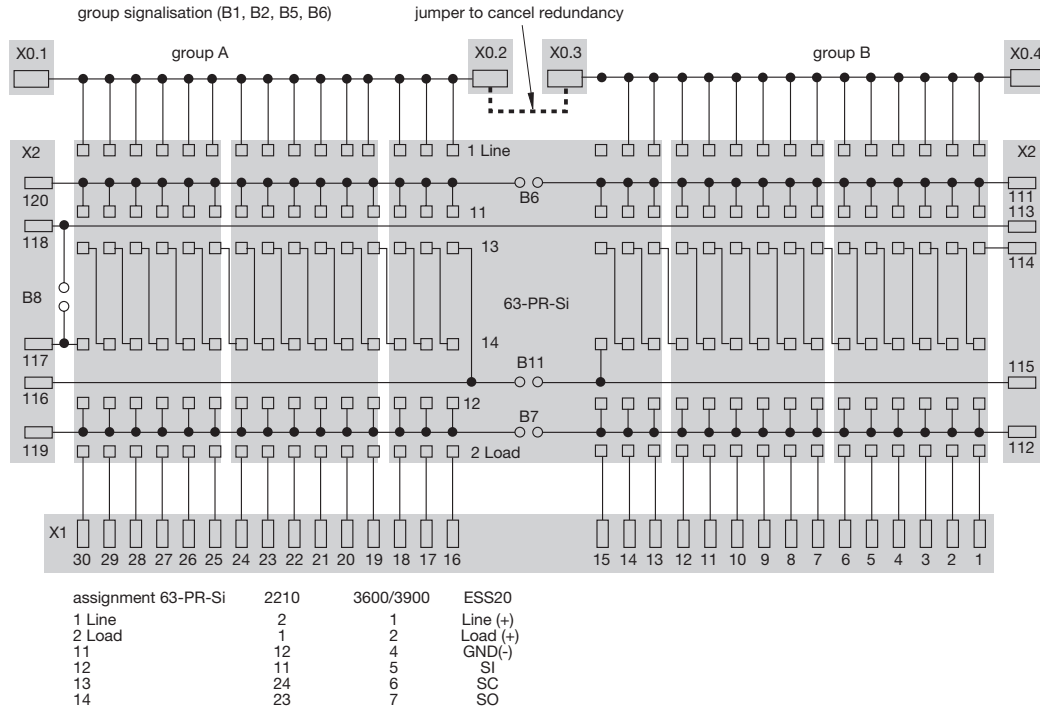

Bus pcb (single pole version)

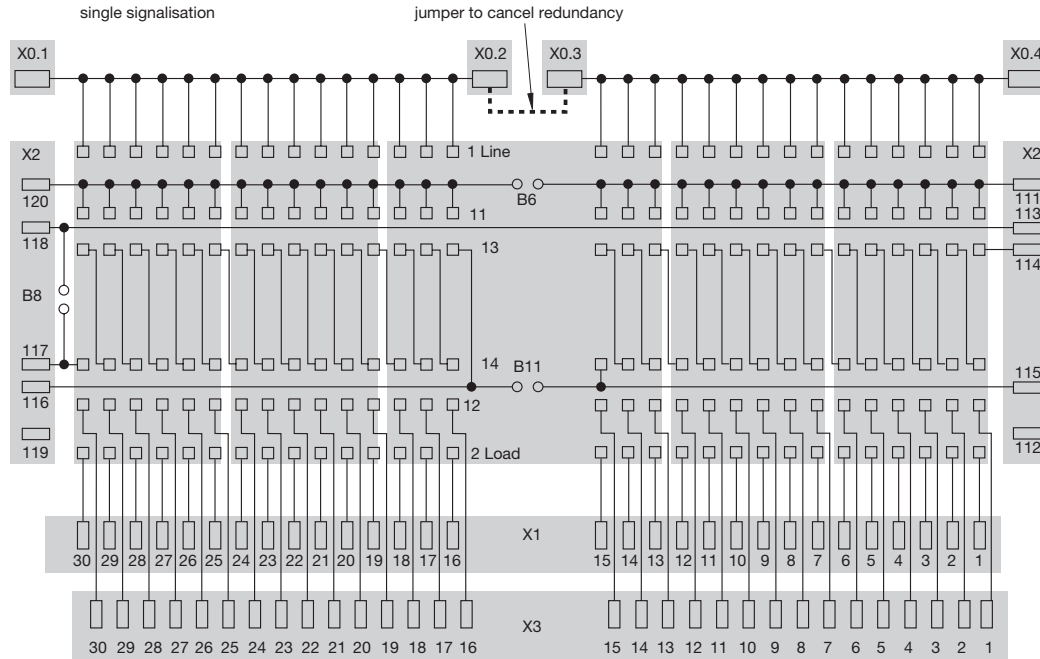

Dimensions

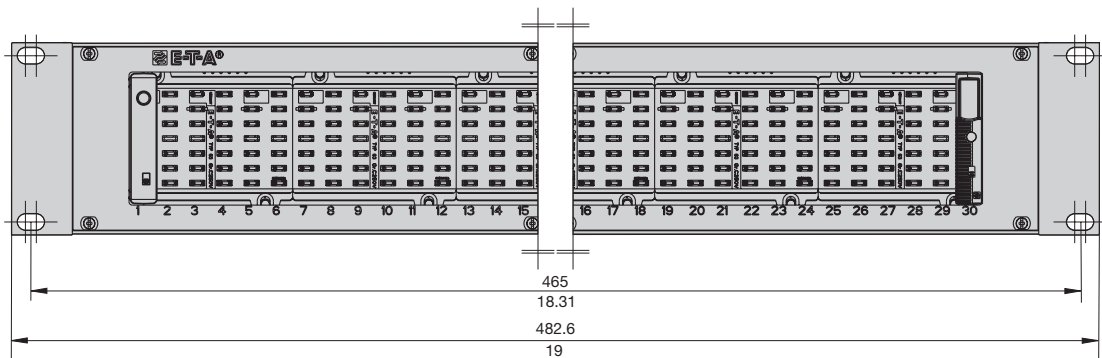
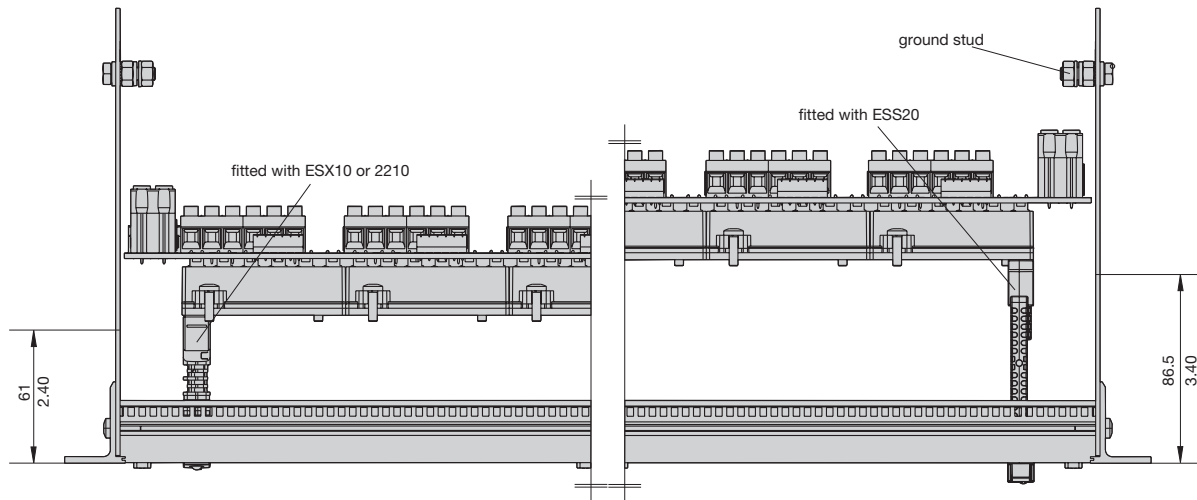
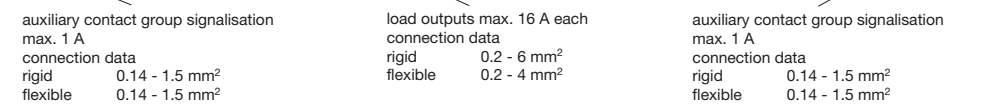
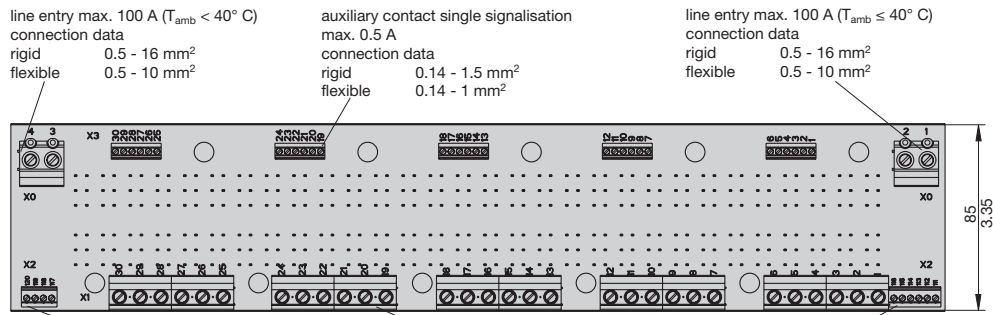

Pin assignment bus pcb (terminal side)

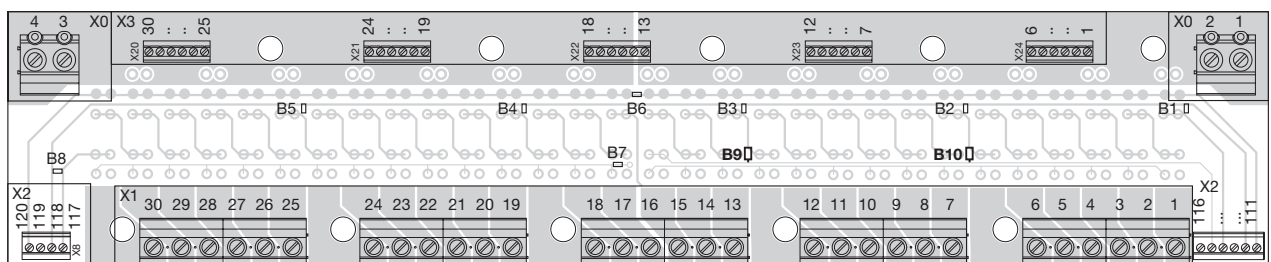

Schematic diagrams

Bus pcb (signalisation B1, B2, B5, B6)

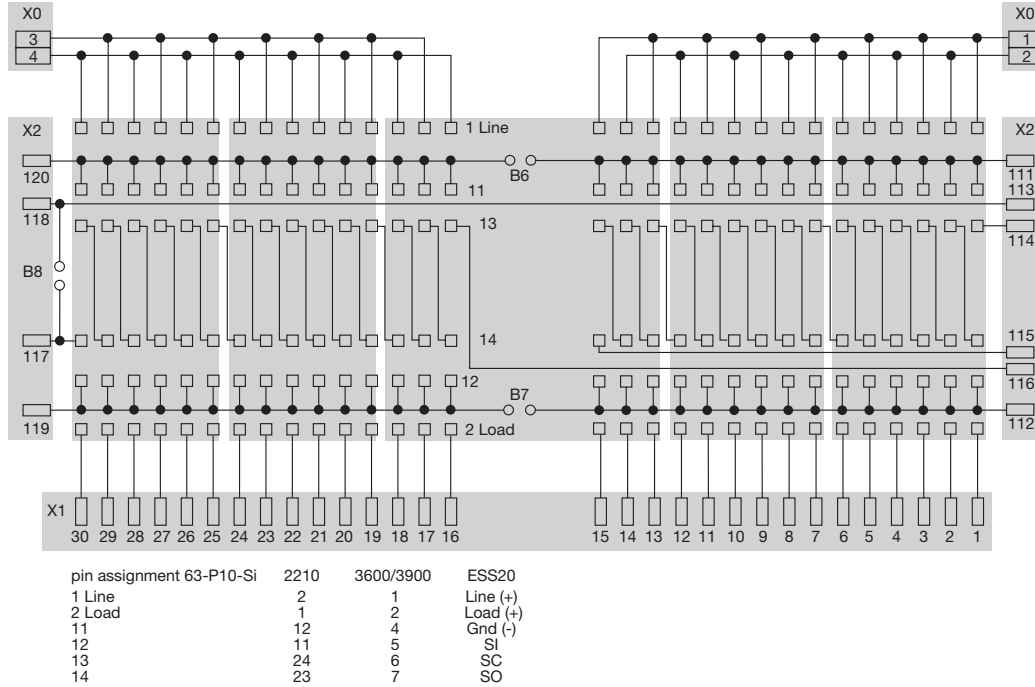

Bus pcb (signalisation B3)

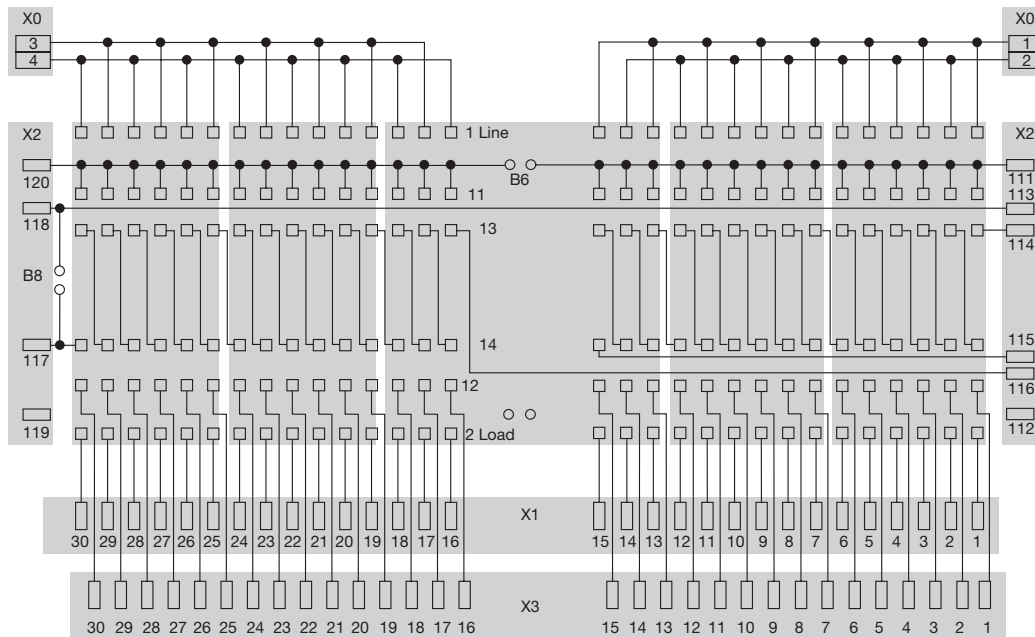

1

Accessories

Blanking piece for Power-D-Box
(types 3600/3900, 2210)
Y 308 563 01

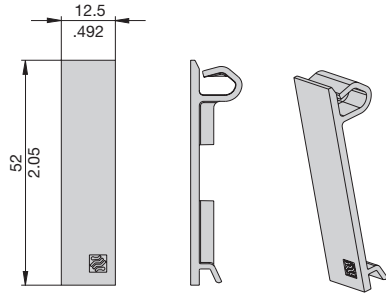

Blanking piece for Power-D-Box
(types ESS20/ESX10)
Y 308 563 41

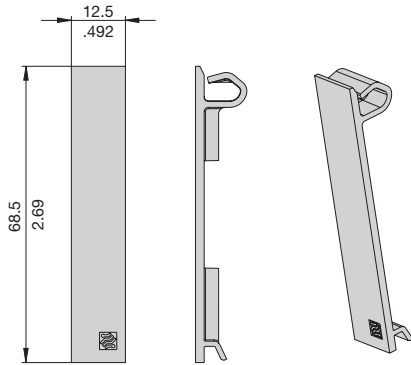

Withdrawal tool for ESS20/ESX10
Y 308 602 01

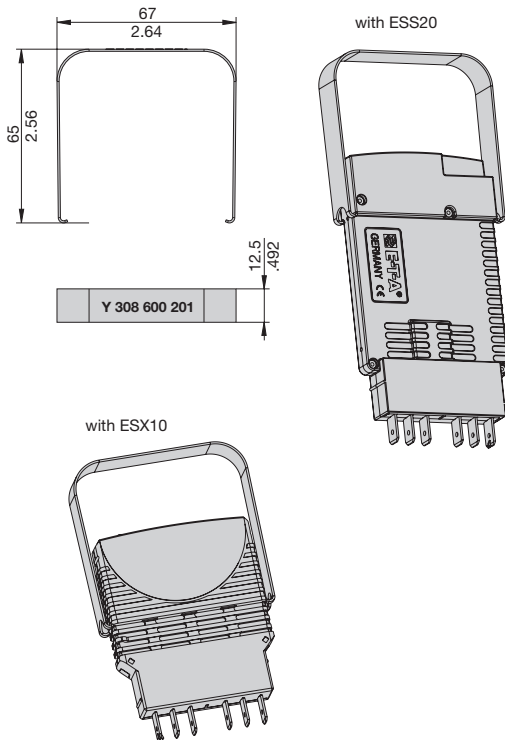

Jumper
to bypass looped through unused auxiliary contacts
(series connection)
X 222 066 01

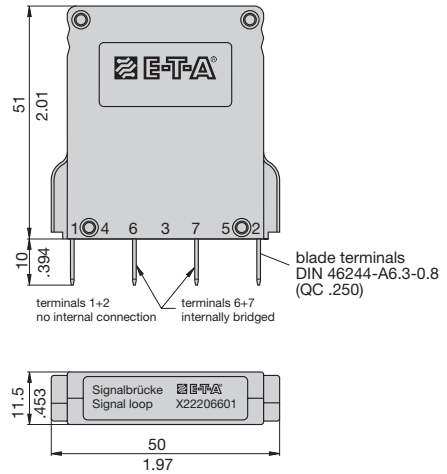

1

This is a metric design and millimeter dimensions take precedence ($\frac{\text{mm}}{\text{inch}}$)

All dimensions without tolerances are for reference only. In the interest of improved design, performance and cost effectiveness the right to make changes in these specifications without notice is reserved. Product markings may not be exactly as the ordering codes. Errors and omissions excepted.