

**Description**

The E-T-A Solid State Remote Power Controllers E-1071-623/627 are electronic control modules suitable for inductive loads such as electromagnetic valves (solenoids), magnetic brakes etc.

They are used:

- for safe and quick switching of loads
- for monitoring the electrical condition of the loads
- for compensating different cable lengths

The load connected to the relay should be operated with a higher voltage (DC 28...60 V) than its rated voltage (DC 24 V) because the load current is controlled electronically (pulse-controlled characteristics). This is to ensure that in industrial plants with different cable lengths (supply cables, load cables) an increased inrush current can be applied to each load. During hold duty the load current is reduced to a smaller value (approx. 60 % of the current rating), thus reducing the operating temperature and extending the life of the loads.

The double pole electronic switching output prevents inadvertent start-up or dangerous machine movements as may arise upon a ground fault in systems with ungrounded power supply ('IT systems') (see EC Machinery Directive or EN 60204 part 1 "Safety of Machinery - Electrical Equipment of Machines", para 9.4.3.1).

**Typical applications**

- Double pole switching of inductive actuators such as electromagnetic valves or magnetic clutches in machinery and equipment
- Monitoring the electrical operability of loads
- Protection and monitoring of load circuit cables
- Status indication, failure indication in load circuit visually (via LEDs or red tripped button) and via potentialfree status outputs
- Double pole split up of the load circuit manually or electrically in the event of overload or short circuit

**Features**

- **Designed for inductive loads (DC 24 V)**
- Individual adjustment to various load currents (standard:  $I_N = 0.1...3.1$  A and/or 10 mA...310 mA)
- Significant reduction of power loss in the load by pulse-controlled characteristics
- Double pole switching output, short-circuit proof (short-circuit limitation); physical disconnection from supply
- Inrush current and holding current monitoring
- Physical isolation:
  - optocoupler in the control circuit
  - physical disconnection of load circuit, manually or in the event of a short circuit
  - optocoupler for status outputs
- Reverse polarity and overvoltage protection in the control, load and status circuits
- Control current indication by YELLOW LED
- O.K. indication by GREEN LED
- Wire break indication by RED LED (load circuit)
- Fault indication by RED LED (short circuit, over/undervoltage, setting error)
- Two status outputs for PLCs for evaluation (status indication, ON indication)
- Quick disconnection (do not connect a free-wheeling diode to the load as the free-wheeling current is controlled electronically) Break time < make time



**E-1071-623**

**Technical data (T<sub>ambient</sub> = 25 °C, U<sub>B</sub> = DC 48 V)**

Rated voltage	DC 48 V
Operating voltage U <sub>B</sub>	DC 28...60 V (see Technical description)
Current rating I <sub>N</sub>	adjustable between 0.1...3.1 A and/or 10...310 mA via switch and potentiometer on the front side
Current consumption I <sub>0</sub> (U <sub>S</sub> = »0«)	typically 16 mA
Residual ripple for all voltages	max. 5 % (3 phase bridge)
Reverse polarity protection	U <sub>B</sub> (terminals 1 and 2), integral fuse
Fail Save	
Insulation voltage	2.5 KV between load circuit, control circuit and status signal circuit
<b>Load circuit</b>	
Load output	NPN transistor, minus switching, pulse-controlled (approx. 180 Hz)
Load rating	DC 24 V/adjustable between 0.1...3.1 A or DC 24 V/adjustable between 10...310 mA up to 10 % more than pickup current
Switch-on current I <sub>E</sub>	typically 60 % of the set rated current I <sub>N</sub>
Holding current I <sub>H</sub>	approx. 4.5 A
Short circuit disconnection current	
Wire break monitoring	in the ON and OFF condition (RED LED)
Physical isolation	2-pole in the load circuit, by manual circuit breaker release or after short circuit disconnection
Current measuring plugs	2 x ø 2 mm (current proportional voltage: 1 V ≙ 1 A)
Free-wheeling circuitry (see Technical description)	integral electronic control with quick disconnection
<b>Control circuit</b>	
Control	optocoupler in control input
Control voltage U <sub>S</sub>	»0« = DC 0...5 V »1« = DC 8.5...35 V
Control current I <sub>S</sub>	typically 5...10 mA
Switching frequency f <sub>max</sub>	1 Hz
Control signal (U <sub>S</sub> = »1«)	YELLOW LED lights (I <sub>control</sub> flowing)
Protection	reverse polarity protection (diode)
<b>Status outputs</b>	
2 signal outputs	ON indication/function indication - physically isolated by optocoupler - transistor outputs, plus switching - auxiliary voltage U <sub>A</sub> : DC 12...60 V - max. 50 mA per output - integral free-wheeling diode - reverse polarity and overvoltage protection
ON indication (terminal 8)	U <sub>S</sub> = »0« : output non-conductive < 70 ms switch-off signal delay U <sub>S</sub> = »1« : output connecting plus potential (term. 10) to term. 8 only as long as load current flows, not with wire break or short circuit < 15 ms switch-off signal delay
Function indication (terminal 9)	fault: output non-conductive no fault: output connecting plus potential (terminal 10) to terminal 9

## Technical data (T<sub>ambient</sub> = 25 °C, U<sub>B</sub> = DC 48 V)

### General data

Ambient temperature	0...+60 °C (without condensation)
Terminals	1071-623: screw terminals 1071-627: screw-less spring-loaded terminals Connection: max. 2 x 2.5 mm <sup>2</sup> solid max. 2 x 1.5 mm <sup>2</sup> flex with sleeve
Housing	clamping plate: polycarbonate GV, blue cover: polycarbonate, black track-mountable to EN 50022-35
Mounting	Self-extinguishing properties to UL 94: V = 0; VDE 0304: grade 1 housing, terminals IP20 DIN 40050
Mounting dimensions	45 x 74 x 128 mm
Mass	approx. 170 g

## Technical description

### Operating voltage U<sub>B</sub>

The max. operating voltage of the SSRPC is approx. DC 60 V. The min. operating voltage required for 24 V solenoids depends on the overall ohmic resistance in the load circuit. The switch-on current is reduced by:

- the voltage drop on the load cable
- the load resistance increasing with the operating temperature of the load.

### Minimum operating voltage U<sub>B min</sub>

I <sub>N</sub>	Cable length	Cable size	U <sub>B min</sub>
1 A	2x50 m/2x100 m/2x200 m/2x300 m	1.5 mm <sup>2</sup>	33/35/37/40 V
		2.5 mm <sup>2</sup>	32/33/35/37 V
2 A	2x50 m/2x100 m/2x200 m/2x300 m	1.5 mm <sup>2</sup>	35/38/44/49 V
		2.5 mm <sup>2</sup>	34/35/39/42 V
3 A	2x50 m/2x100 m/2x200 m/2x300 m	1.5 mm <sup>2</sup>	37/41/50/58 V
		2.5 mm <sup>2</sup>	35/38/42/48 V

The load capacity is no longer ensured when the minimum operating voltage falls below U<sub>B min</sub> = 28 V. The RED LED (fault) will indicate and the output will be switched off. Only when an operating voltage of 29.4 V is exceeded will the load be switched on again and normal operation status is restored.

Resistance increase in the load circuit:

1.5 mm <sup>2</sup> cable	approx. 2.8 Ω/100 m distance
2.5 mm <sup>2</sup> cable	approx. 1.6 Ω/100 m distance

### Maximum operating voltage U<sub>B max</sub>

The load capacity is no longer ensured when the max. operating voltage U<sub>B max</sub> = 60 V is exceeded. The RED LED (fault) will indicate and the output will be switched off. Only when the operating voltage falls below 57 V will the load be switched on again and normal operation status is restored.

### Switch-on current I<sub>E</sub> = pickup current

The output transistor connects the operating voltage to the inductive load until actual switch-on of the solenoid (pickup current). After this period the load current is set back to holding current I<sub>H</sub>.

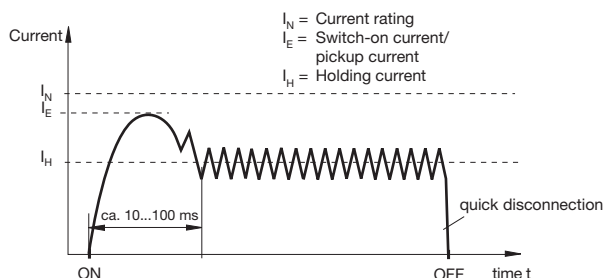

## Technical description

### Rated current I<sub>N</sub>, hold current I<sub>H</sub>

The current rating of the applicable load at its rated voltage should be set between 0.1...3.1 A. The holding current of the load is internally adjusted to 60 % of the set current rating. This holding current can be measured by means of a voltmeter connected to the 2 mm current measuring plugs (current-proportional voltage: 1 V ≙ 1 A).

### Setting the current rating (adjustable between 0.1...3.1 A)

The current rating is set by means of a rotary switch (switch setting 0 A - 1 A - 2 A) and a 270° potentiometer (setting range between 0.1...1.1 A). The sum of the two settings should equal the current rating of the load.

**Example:** 24 V load with I<sub>N</sub> = 1.5 A

**Setting:** switch 1 A + potentiometer 0.5 A

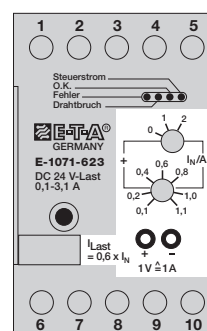

### Faulty setting of current rating

The red LED (failure indication) blinks in the event of a faulty setting. The load is disconnected only after approx. 15 sec if the current rating value is not corrected and the red LED will be permanently lighted. Reset is only possible by switching on again.

The tolerance range, in which faulty setting will not be indicated, is approx. ± 30 % of the holding current.

## Ordering information

Type No.	
E-1071	SSRPC
Terminals	
623	screw terminals
627	screw-less connectors
Voltage rating of load	
DC 24 V	
Current rating	
0.1 A...3.1 A (standard)	
0.01 A...0.31 A	
E-1071 - 623 - DC 24 V - 0.1 A...3.1 A ordering example	

**Operating modes**

mode	fault-free		wire break		load short circuit -HSS to GND <sup>1</sup> -LSS to U <sub>B</sub> <sup>2</sup>		U <sub>B</sub> too low/ high <sup>3</sup>	
	»0«	»1«	»0«	»1«	»0«	»1«	»0«	»1«
control input (terminals 6 and 7)	»0«	»1«	»0«	»1«	»0«	»1«	»0«	»1«
LED YELLOW – control c.	0	1	0	1	0	1	0	1
LED GREEN - O.K.	1	1	0	0	0	0	0	0
LED RED - wire break	0	0	1	1	0	0	0	0
LED RED - fault	0	0	0	0	1	1	1	1
status function (terminal 9)	1	1	0	0	0	0	0	0
status operation (terminal 8)	0	1	0	0	0	0	0	0
physical isolation	0	0	0	0	1	1	0	0

**Notes:**

- 1 Short circuit HSS to GND: plus-switching transistor connected to ground
- 2 Short circuit LSS to U<sub>B</sub> : minus-switching transistor connected to U<sub>B</sub>
- 3 Underoltage: device disconnects at 28 V and reconnects at 29.4 V  
Overvoltage: device disconnects at 60 V and reconnects at 57 V

- 1 - LED status output carries to plus potential
- 0 - LED status output is non-conductive

**Schematic diagram**

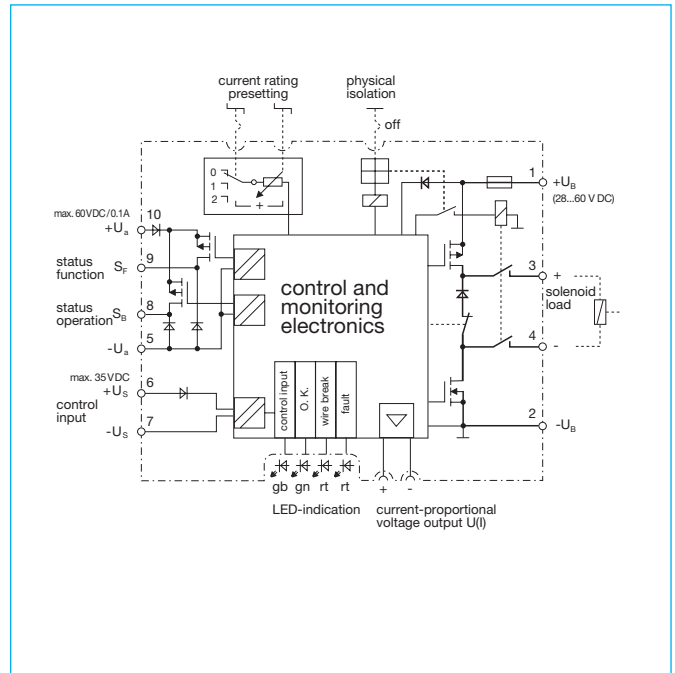

**Dimensions**

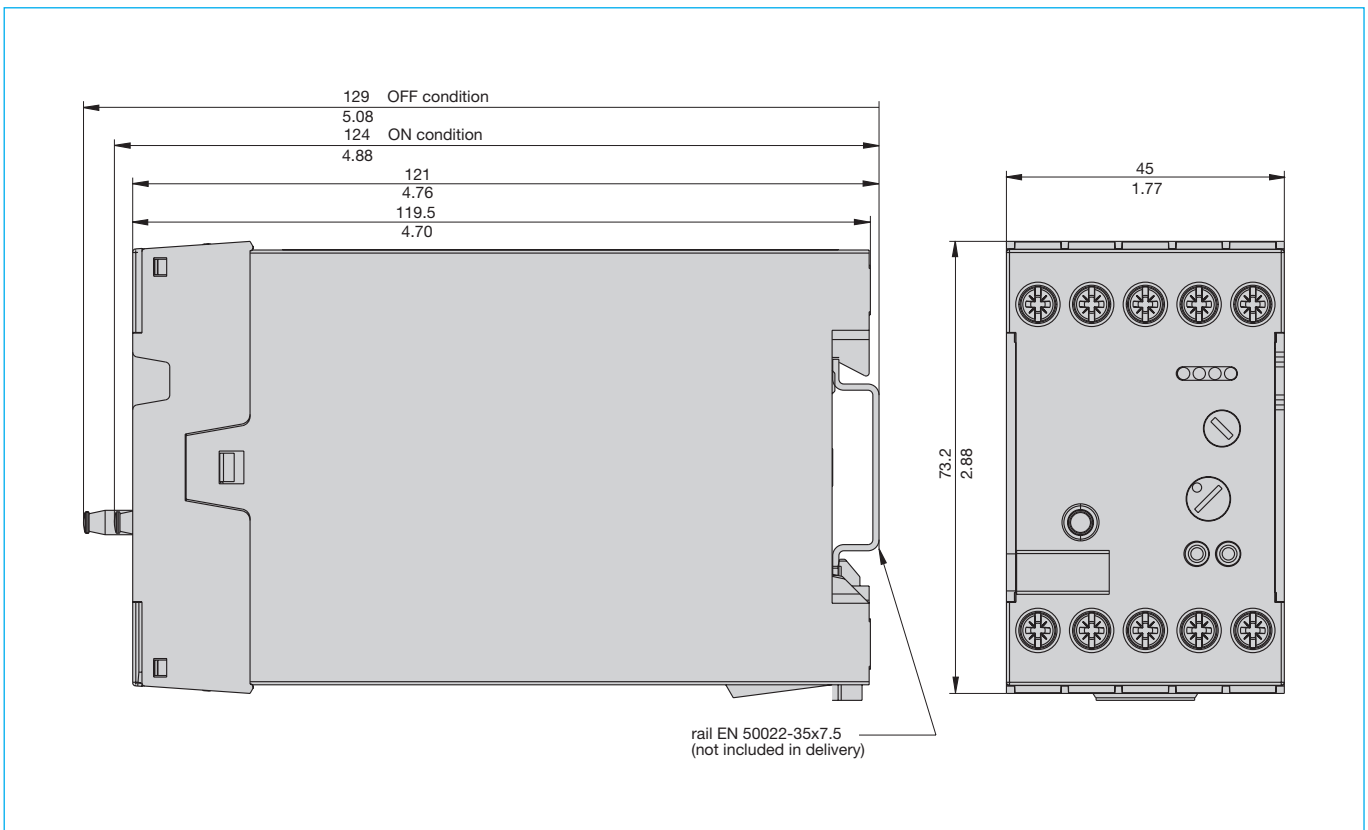

This is a metric design and millimeter dimensions take precedence (mm/inch)

Terminal selection

E-1071-623 (0.1 - 3.1 A)

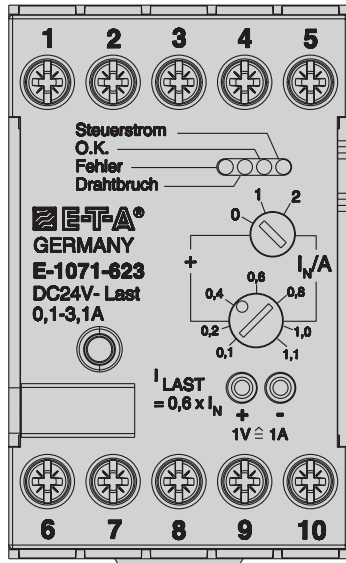

E-1071-623 (10 - 310 mA)

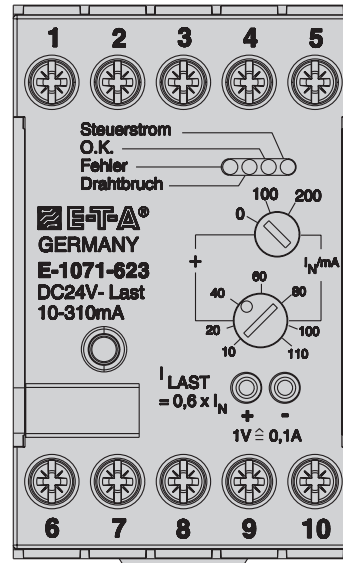

E-1071-627 (0.1 - 3.1 A)

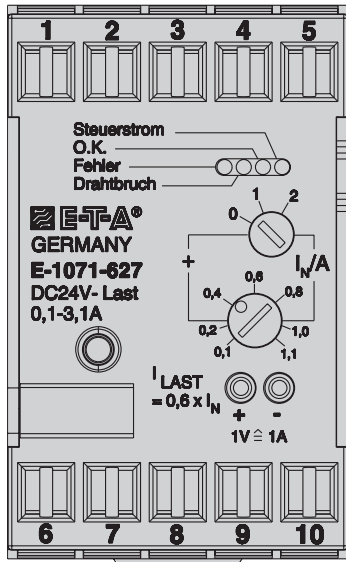

E-1071-627 (10 - 310 mA)

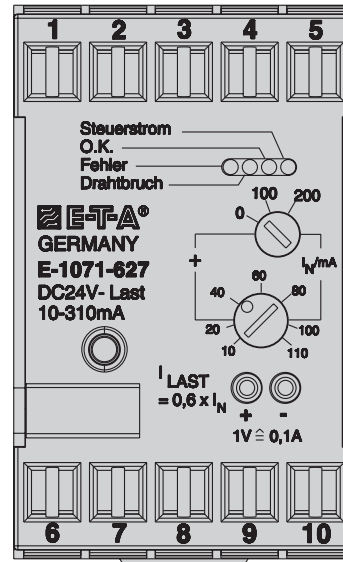

Terminal:

- 1 Operating voltage +U<sub>B</sub>: max. DC 60 V
- 2 Operating voltage (-)
- 3 Load (+)
- 4 Load (-)
- 5 Auxiliary voltage -U<sub>A</sub> for status outputs
- 6 Control voltage +U<sub>S</sub>: max. 35 V
- 7 Control voltage -U<sub>S</sub>
- 8 Status output "operation" (max. 50 mA)
- 9 Status output "function" (max. 50 mA)
- 10 Auxiliary voltage +U<sub>A</sub> for status outputs: max. DC 60 V/100 mA)

**Application note:**  
**Controlling and monitoring of solenoid valves in combination with LED valve plugs**

Possible configuration of E-1071-62x

- A) with screw terminals: E-1071-623-DC 24 V-0.1...3.1 A  
 with screwless terminals: E-1071-627-DC 24 V-0.1...3.1 A
- B) with screw terminals: E-1071-623-DC 24 V-0.01...0.31 A  
 with screw terminals: E-1071-627-DC 24 V-0.01...0.31 A

Often DC 24 V solenoids with a low power rating are used which are to be controlled and monitored by the above mentioned devices. Sometimes these solenoids are fitted with solenoid valve plugs, e.g. made by Hirschmann, and hold a small electronic pcb

- with LED,
- a series resistor
- a protective diode connected in anti-parallel to the LED

The following components can be recommended:

- Recommended valve plugs with LED, Hirschmann
  - type GDML 2011 LED 24 YE, contains the pcb
  - type GDME-LED 24 YE
  - type GDML 2011 LED 24 RD, contains the pcb
  - type GDME-LED 24 RD

status indication (LED) with a protective diode connected in anti-parallel

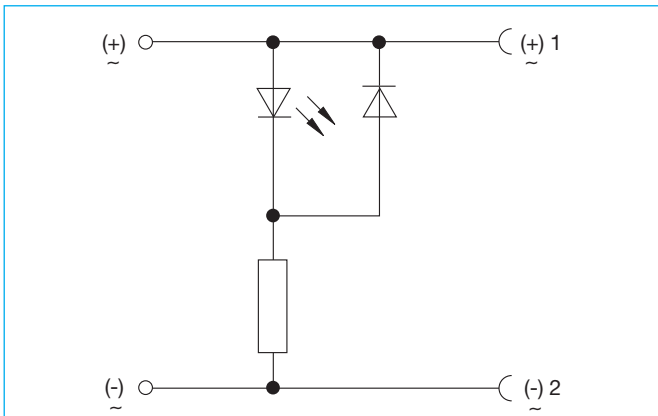

- Recommended adapter with LED, Murr Elektronik
  - suppressor element model B – 10 mm LED, 24 V DC/50 VA/W, part no.: 3124875
  - suppressor element model BI – 11 mm LED, 24 V AC/DC/50 VA/W, part no.: 3124215
  - suppressor element model C – 8 mm LED, 24 V AC/DC/50 VA/W, part no.: 312811

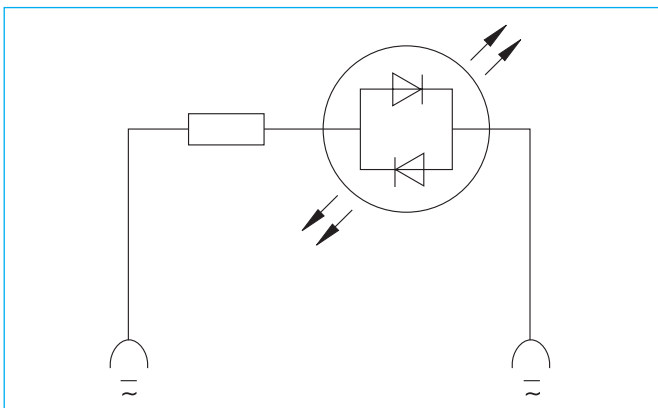

**Please note:**

- **In the event of using a plug or suppressor element not recommended, the wire break monitoring function might be limited in the not activated condition.**

● **Solenoid valves < 5 W**

Reliable switching behaviour of the SSRPC can only be ensured for solenoid valves < 5 W if SSRPCs type B = E-1071-62x-DC 24 V-0.01...0.31 A are used.

LED connection in valve plug is generally possible with solenoid valves < 5 W.

**LED current has to be added to coil current when selecting the rating.**

● **Solenoid valves 5 W plus to 75 W**

Please use SSRPC type A = E-1071-62x-DC 24 V-0.1...3.1 A for this range.

LED connection in valve plug is generally possible with solenoid valves 5 W plus to 75 W.

All dimensions without tolerances are for reference only. In the interest of improved design, performance and cost effectiveness the right to make changes in these specifications without notice is reserved. Product markings may not be exactly as the ordering codes. Errors and omissions excepted.