

Description

Three pole, miniaturised, aircraft style thermal circuit breaker with tease-free, trip-free, snap action mechanism and push/pull on/off manual actuation (M-type TO CBE to EN 60934). An indicator band on the push button clearly shows the tripped/off position. Threadneck panel mounted, available in metric and US (AS 14154) configurations. Advanced two-chamber design minimises contact contamination to provide fail-safe operation. Temperature compensated with optional auxiliary contacts, and fully approved for use on a wide range of aircraft and equipment. For single pole version see type 483.

Typical applications

Aircraft systems and equipment (fixed wing and helicopters); other extra low voltage wiring applications; defence equipment; communications systems.

Standard current ratings and typical volt drop values

Current rating (A)	Volt drop per pole (mV)	Current rating (A)	Volt drop per pole (mV)
1	750	7.5	230
2	520	10	190
2.5	400	15	190
3	360	20	200
4	350	25	170
5	260	30	160

Approvals

LN 29887
 VG 95345, part 11
 prEN 2996
 AS 14154
 QPL



Technical data

Voltage rating	3 AC 200 V (400 Hz); DC 28 V	
Current rating range	1...30 A	
Auxiliary circuit	0.5 A, DC 28 V	
Typical life	20,000 operations mechanical 10,000 operations at I_N (≤ 25 A) 4,000 operations at I_N (30 A)	
Ambient temperature	-55...+125 °C (-67...+257 °F) ≤ 15 A -55...+90 °C (-67...+194 °F) > 15 A	
Insulation co-ordination (IEC 60664 and 60664A)	rated impulse withstand voltage 1.5 kV	pollution degree 3
Dielectric strength (IEC 60664 and 60664A)	test voltage operating area pole/pole main to aux. circuit	AC 1,500 V AC 1,500 V AC 1,500 V
Insulation resistance	> 100 M Ω (DC 500 V)	
Interrupting capacity I_{cn} 3 AC 200 V (400 Hz):	≤ 4 A 5 A 7.5...25 A 30 A	1,000 A 2,000 A 2,500 A 1,500 A
	DC 28 V:	1...25 A 30 A 4,000 A
Degree of protection (IEC 60529/DIN 40050)	operating area IP40 terminal area IP00	
Vibration (sinusoidal)	10 g (57-2000 Hz), ± 0.76 mm (5-57 Hz) to VG 95210, sheet 19, IEC 60068-2-6, test Fc, ISO 7137	
Vibration (random)	16.4 g rms, 0.2 g ² Hz ± 1.5 dB, to VG 95210, sheet 29, IEC 60068-2-6, test Fc, ISO 7137	
Acceleration	17 g, to ISO 2669	
Shock	50 g (11 ms), to VG 95210, sheet 28, IEC 60068-2-27, test Ea, ISO 7137	
Corrosion	96 hours at 5 % salt mist 48 hours at 20 % salt mist to VG 95210, sheet 2, IEC 60068-2-11, test Ka, ISO 7137	
Humidity	240 hours at 95 % RH, to VG 95210, sheet 7, IEC 60068-2-3, test C/ISO 7137	
Explosion	to VG 95210, sheet 10, MIL-STD-202, meth. 109	
Altitude	$\leq 25,000$ m above sea level	
Mass	max. 67 g with auxiliary contact max. 63 g without auxiliary contact	
Mass reduction through aluminium threadneck approx. 3 g		

Ordering information

Type No.

583 three pole, with temperature compensation

Mounting

G threadneck panel mounting

Threadneck design

- 1 M12x1x6.4x8.8 dia. with mounting plate (aux. contact version)
- 3 MJ12x1x6.4x8.8 dia. (only without aux. contact)
- 4 M12x1x6.4x8.8 dia. (only without aux. contact)
- 5 7/16-32UNx6.4x7.8 (only without aux. contact)
- 7 7/16-32 UNx6.4x7.8 dia. with mounting plate (aux. contact version)
- 8 M12x1x6.4x8.8 with mounting plate, aluminium threadneck
- 9 M12x1x6.4x8.8, aluminium threadneck

Hardware for threadneck (washers)

- 0 without hardware
- 1 corrugated washer 12/15, fitted
- 2 serrated lock washer 12.1/17.2, fitted
- 3 toothed washer 11.3/14.9, fitted
- 5 serrated lock washer 12.1/17.2, bulk shipped

Hardware for threadneck (nuts)

- 0 without hardware
- 1 hex nut M12x1
- 3 hex nut 7/16-32UN
- 5 hex nut MJ12x1 (only with threadneck design 3)
- 7 hex nut M12x1, aluminium, bulk shipped

Terminal design (main terminals)

- K screw terminals with metric thread
 - 1 K14 (M4, MJ4)
- J screw terminals with inch thread
 - 1 J14 (8-32UNC-2B)

Characteristic curve

M1 thermal, 1.15-1.38 I_N

Terminal screws

- A Phillips screw M4x6
- B Phillips screw 8-32UNC-2Ax6 (MS 51957-41)
- K hex screw with Phillips head 8-32UNC-3Ax7.6
- L Phillips screw MJ4x6
- Z without accessories

Terminal washers

- 0 without lock washer
- 1 lock washer B4
- 2 lock washer 4.3 (MS 35338-137)
- 5 lock washer 4.3/9

Auxiliary contact

- S0 without auxiliary contact
- S1 with auxiliary contact (N/C) (connector to EN 3155-016M2018, size 20)
- S5 with polarized auxiliary contact (N/C)

Barrier

- T barrier 25.5 mm wide, 37.7 mm long (-S0 only)
- U barrier 19.5 mm wide, 37.7 mm long
- X barrier 19.5 mm wide, 34.1 mm long

Colour of the push button

- (blank) black (standard) (e.g. 7.5)
- G green to EN (e.g. 7 1/2)
- N black to EN (e.g. 7 1/2)

Current ratings

1...30 A

583 - G 4 1 1 - K 1 M1 - A 1 S0 T . - 5 A ordering example

Ordering information for approved devices

583-G411-K1M1-A1S0TN (583-96-TC-K14)

Metric threadneck M12x1 and terminal design -K14 (M4x6), listed by the German Materialamt der Bundeswehr to VG 95345 T11.

583-G533-J1M1-B2S0XN (AS 14154)

Threadneck size 7/16-32UNx6.4 and terminal design -J14 (inch thread 8-32), approved to AS 14154.

Dimensions 583-G411-K1M1-A1S0TN (VG 95345 T11)

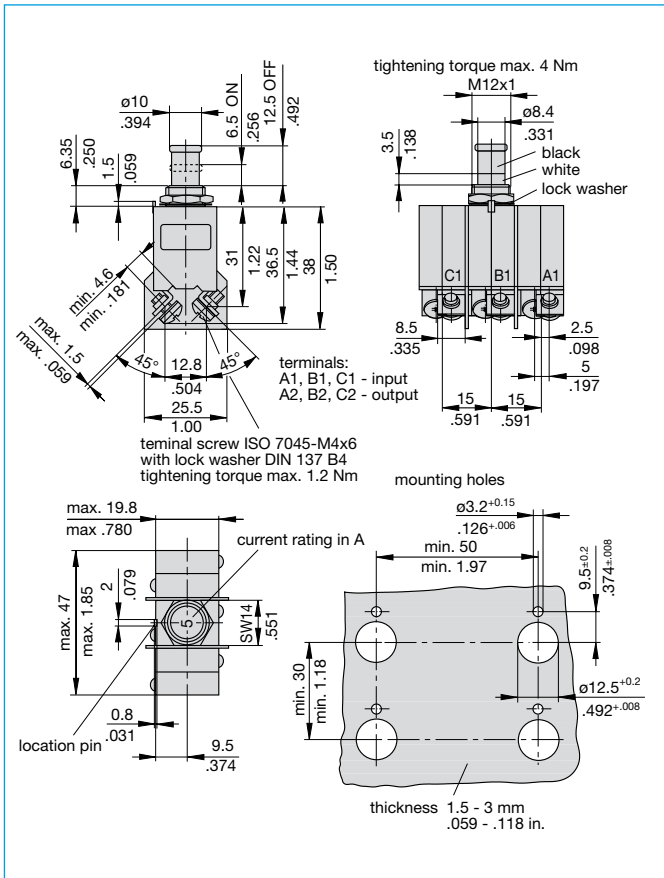

Dimensions 583-G533-J1M1-B2S0XN (AS14154)

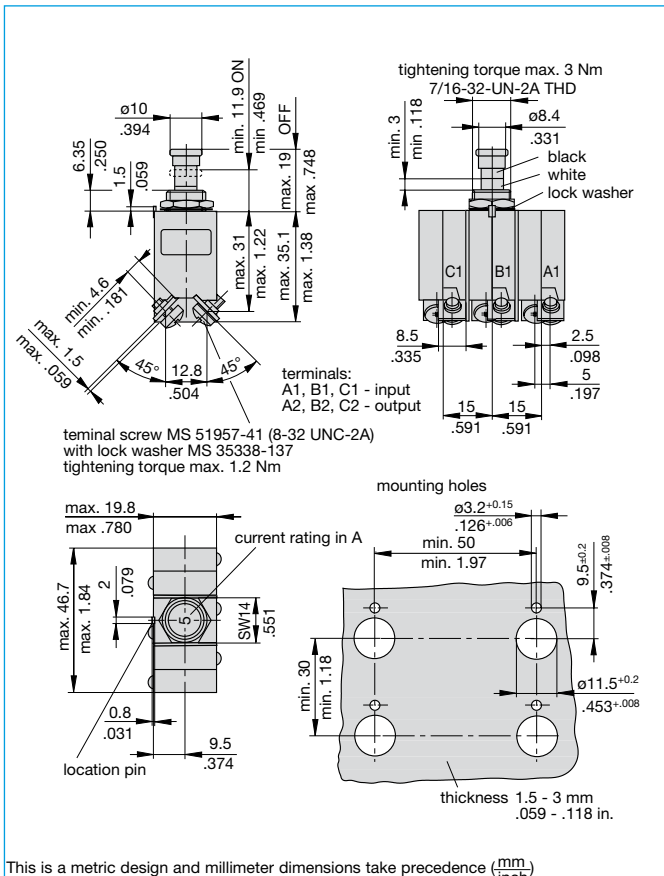

Dimensions 583-G111-K1M1-A1S1UN (VG 95345 T11)

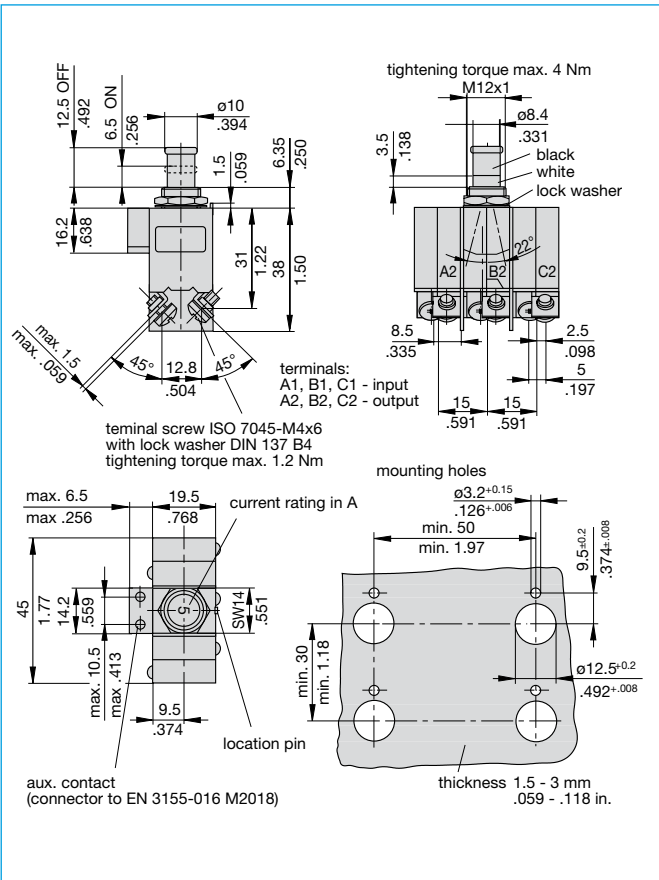

Typical time/current characteristics

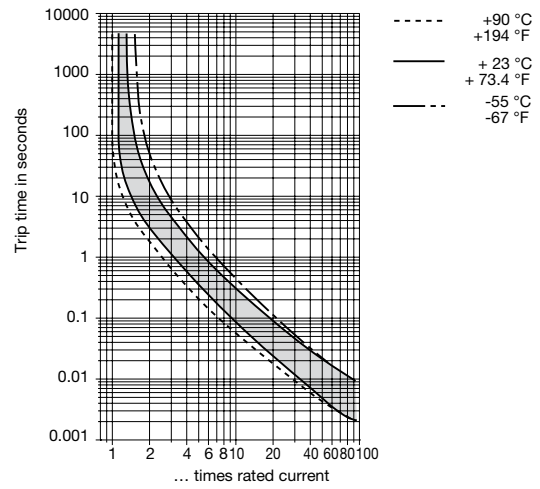

Internal connection diagrams

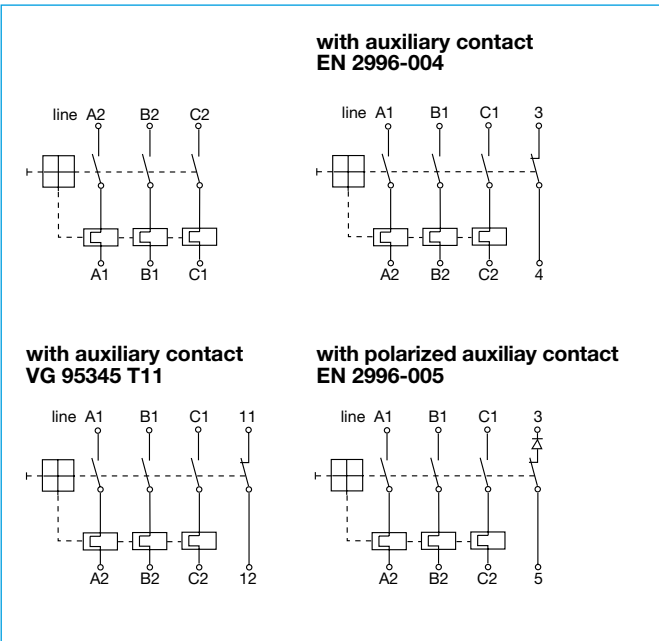

Accessories

Splash cover/hex nut assembly with O ring (IP66 and IP67)
 (approved to VG 95345, part 23)
X 200 801 08 nickel plated nut, transparent cover
X 200 801 03 matt black finish nut, black cover
X 200 801 09 matt black finish nut 7/16-32, black cover

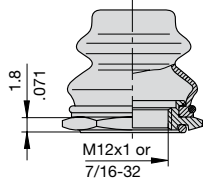

Splash cover black/hex nut assembly with O ring (IP54)
 only for threadneck nut M12 (to VG 95345, sheet 23)
X 200 802 01 nickel plated nut
X 200 802 02 matt black finish nut

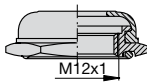

Actuator extension (black) to be fitted on the push button
 (approved to VG 95345, T23)
X 200 803 01

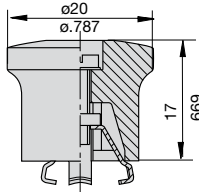

Identification collar to be snapped on the push button
Y 307 004 01 black
Y 307 004 02 white
Y 307 004 03 red
Y 307 004 04 green
Y 307 004 05 blue

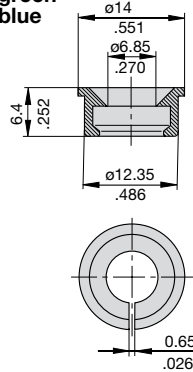

Lock out ring to block the push button in OFF position
Y 307 005 01 red
Y 307 005 02 black

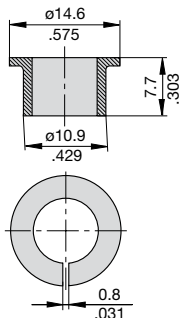

This is a metric design and millimeter dimensions take precedence ($\frac{\text{mm}}{\text{inch}}$)

All dimensions without tolerances are for reference only. In the interest of improved design, performance and cost effectiveness the right to make changes in these specifications without notice is reserved. Product markings may not be exactly as the ordering codes. Errors and omissions excepted.