

Description

Three pole, aircraft style thermal circuit breaker with trip-free mechanism and push/pull on/off manual actuation. An indicator band on the push button clearly shows the tripped/off position. Threadneck panel mounted, temperature compensated, with optional auxiliary contacts. The robust design is well suited to extremely harsh conditions. In the event of an overload in one, two or three phases all three poles will be disconnected.

Typical applications

Land vehicles, aircraft, watercraft, special vehicles.

Ordering information

Type No.

5140 High performance thermal circuit breaker with temperature compensation

Mounting

G threadneck panel mounting

Threadneck design

- 1** M12x0.75x7 alu, blackened, 1 location pin
- 2** M12x0.75x7 alu, blackened, 2 location pins

Number of poles

3 3-pole, protected

Hardware for threadneck

3 hex nut M12x0.75, alu, serrated lock-washer 12.1/17.2, bulk

Terminal design (main terminals)

- J1** screw terminals with inch thread (8-32UNC-2B)
- J2** screw terminals with inch thread (8-32UNC-2B) on one side, busbar terminals on other side, with hole bent at 60°
- J3** screw terminals with inch thread (8-32UNC-2B) on one side, busbar terminals on other side, with hole bent at 40°

Characteristic curve

M1 thermal 1.1 - 1.45 I_N

Accessories terminal screws & terminal washers

M6 hex screw with Phillips head 8-32UNC-3Ax7.6 & lock washer 4.3/9 bulk

Z0 without accessories

Auxiliary contact

S0TN without auxiliary contact, with barrier, black

S5TN with aux. contact (N/C) (female contact for male contacts to EN3155-016M2018), with barrier, black

Current ratings

20...50 A

5140 - G 1 3 3 - J1 M1 - M6 S5TG-20 A ordering example



without auxiliary contact

with auxiliary contact

5140

Technical data

Voltage rating	3 AC 200 V (400 Hz); DC 28 V	
Current rating range	20...50 A	
Auxiliary circuit	0.5 A, DC 28 V	
Typical life	5,000 operations mechanical and 2,500 operations at I _N	
Ambient temperature	-55...+125 °C (-67...+257 °F)	
Temperature compensation	-55...+90 °C (-67...+194 °F)	
Insulation co-ordination (IEC 60664)	rated impulse withstand voltage 1.5 kV	pollution degree 3
Dielectric strength	test voltage operating area pole/pole main to aux. circuit AC 1,500 V AC 1,500 V AC 1,500 V	
Insulation resistance	> 100 MΩ (DC 500 V)	
Interrupting capacity I _{cn}	2,000 A	
Degree of protection (IEC 60529)	operating area IP40 terminal area IP00	
Vibration (sinusoidal)	± 0.76 mm (5-80 Hz) 10 g (80-500 Hz), 5 g (500-2000 Hz) to EN 2350 Abschn. 5.3.1 and ISO 7137	
Vibration (random)	0.04 g ² /Hz (40-500 Hz) 5.8 g rms (10-2000 Hz) to ISO 7137	
Acceleration	17 g, to EN 2350, para 5.3.3 and ISO 2669	
Shock	50 g (11 ms), to EN 2350 para 5.3.2 and ISO 7137	
Corrosion	48 hours at 5 % salt mist to EN 2350 para 5.4.2 and ISO 7137	
Humidity	240 hours at 95 % RH, to EN 2350 para 5.4.3 and ISO 7137	
Altitude	≤ 15,000 m above sea level	
Mass	ca. 144 g with accessories and without auxiliary contact ca. 150 g with accessories and with auxiliary contact	

E-T-A® High Performance Thermal Circuit Breaker 5140

Standard current ratings and typical volt drop values

Current rating (A)	Volt drop per pole (mV)
20	150
25	150
30	150
35	150
40	120
45	120
50	120

Approvals

ASNE 0459
NSA 931323
EN 3662-005
EN 3662-006

Internal connection diagrams

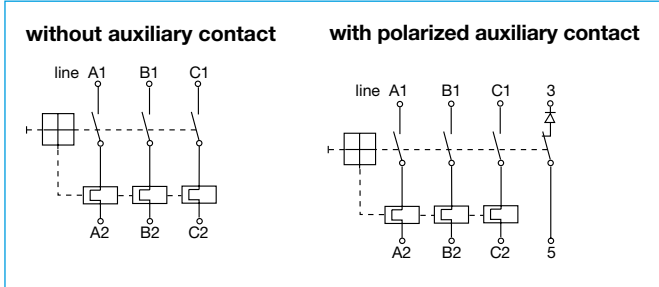

Typical time/current characteristics

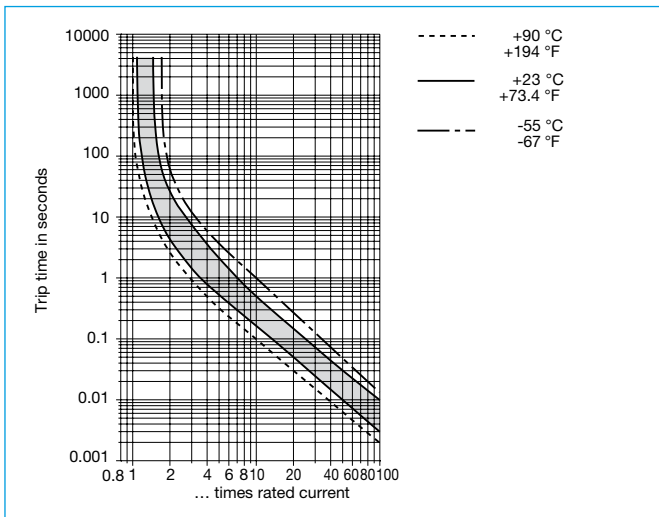

This is a metric design and millimeter dimensions take precedence ($\frac{\text{mm}}{\text{inch}}$)

Dimensions

5140-G132-J1M1-Z0S0TN (NSA 931 323; prEN 2665-004)
5140-G132-J1M1-M6S0TN (NSA 931 323; prEN 2665-004)

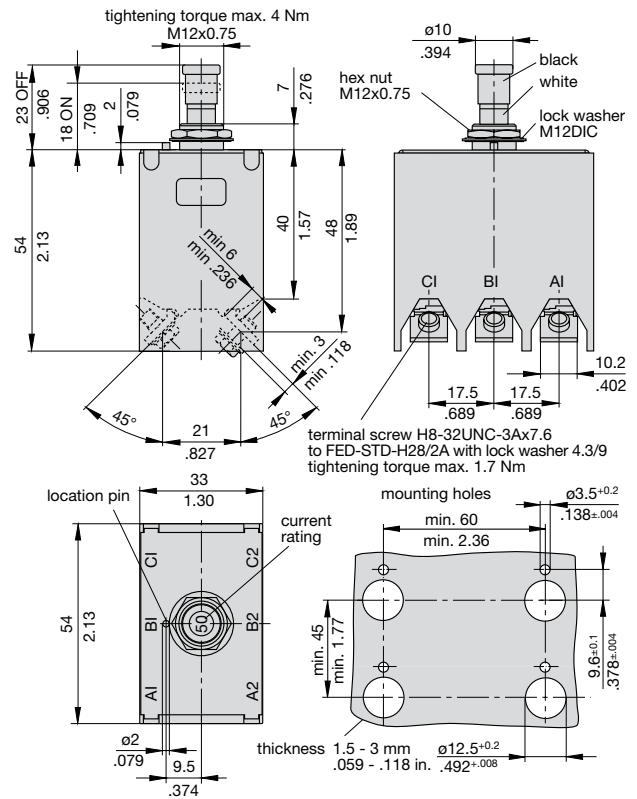

5140-G132-J1M1-Z0S5TG (ASNE 0733-005; EN 3662-005)
5140-G132-J1M1-M6S5TG (ASNE 0733-005; EN 3662-005)

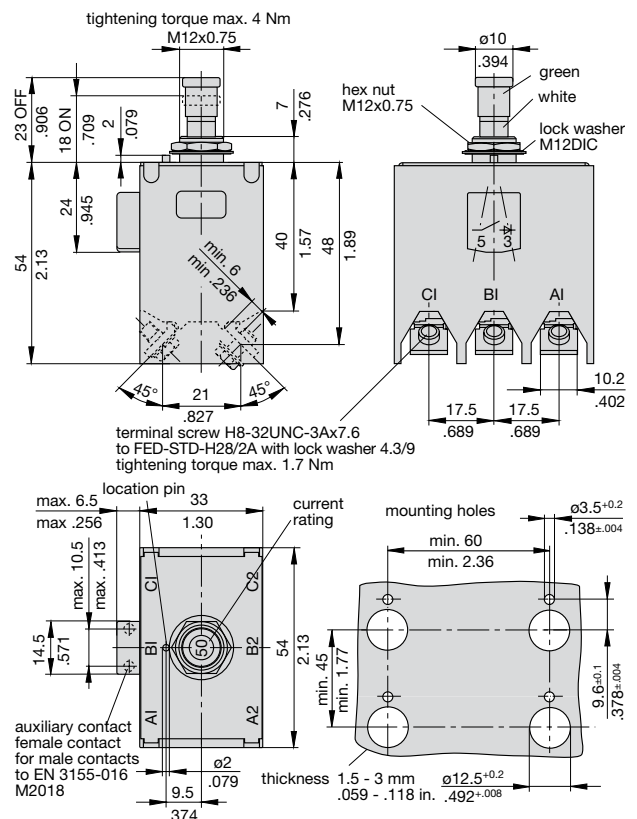

Dimensions

5140-G132-J2M1-ZOS0TN (ASNE 0459) 5140-G132-J2M1-M6S0TN (ASNE 0459)

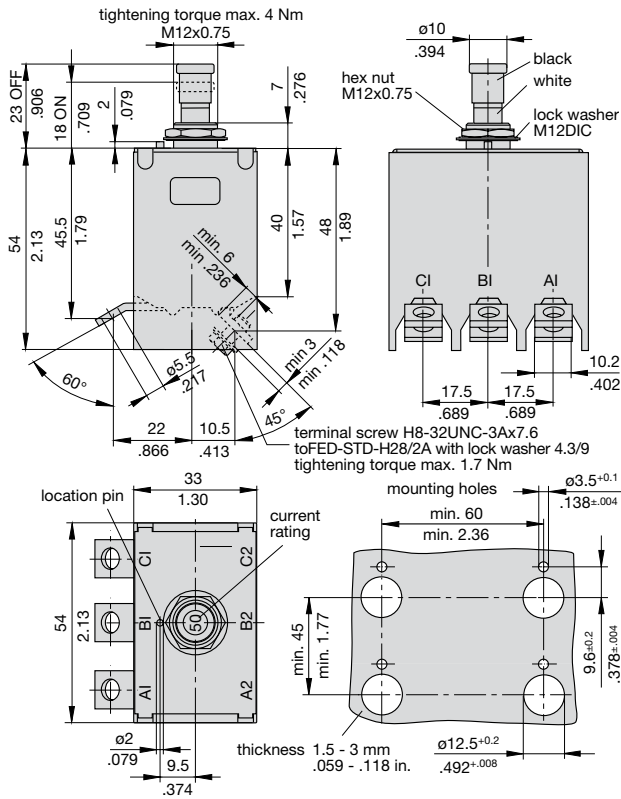

5140-G232-J3M1-ZOS5TG (ASNE 0733-006; EN 3662-006) 5140-G232-J3M1-M6S5TG (ASNE 0733-006; EN 3662-006)

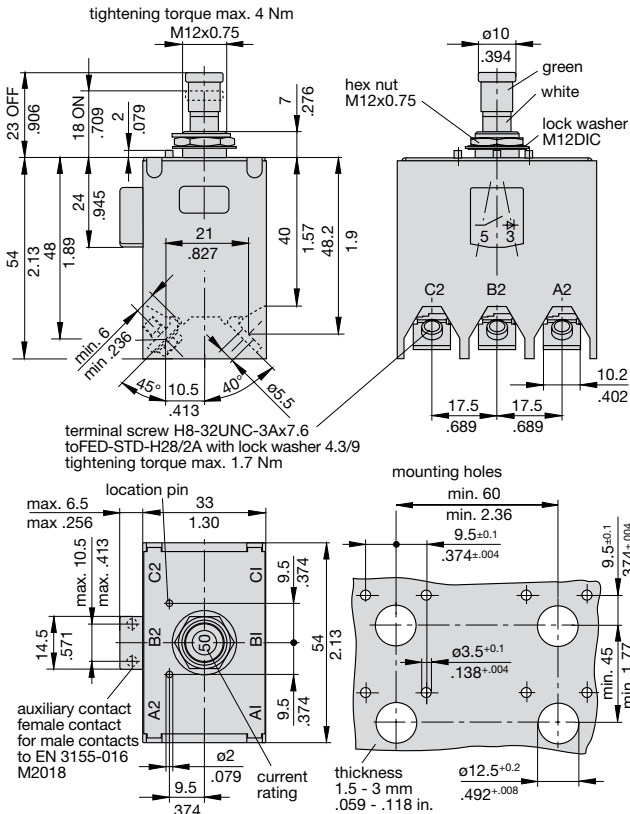

Accessories

Splash cover/hex nut assembly with O ring (IP66 and IP67)
X 200 801 15 black anodised nut M12x0.75x6, black cover

Splash cover/hex nut assembly with O ring (IP66 and IP67)
X 200 801 16 black anodised nut 7/16-32UNx6, black cover

Splash cover/hex nut assembly with O ring (IP66 and IP67)
X 200 801 17 black anodised nut 7/16-32UNx6,
transparent cover

Splash cover/hex nut assembly with O ring (IP66 and IP67)
X 200 801 18 black anodised nut M12x0.75x6,
transparent cover

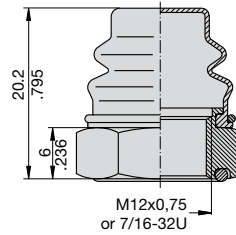

Actuator extension (black) to be fitted on the push button
X 200 803 01 (approved to VG 95345, part 23)

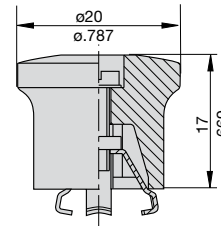

Identification collar to be snapped on the push button
Y 307 004 01 black
Y 307 004 02 white
Y 307 004 03 red
Y 307 004 04 green
Y 307 004 05 blue

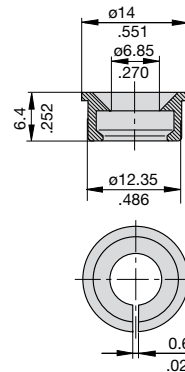

This is a metric design and millimeter dimensions take precedence ($\frac{\text{mm}}{\text{inch}}$)

All dimensions without tolerances are for reference only. In the interest of improved design, performance and cost effectiveness the right to make changes in these specifications without notice is reserved. Product markings may not be exactly as the ordering codes. Errors and omissions excepted.